

සියලු ම හිමිකම් ඇවිරිණි/முழுப் பதிப்புரிமையடையது/All Rights Reserved]

ශ්‍රී ලංකා විභාග දෙපාර්තමේන්තුව ශ්‍රී ලංකා විභාග දෙපාර්තමේන්තුව ශ්‍රී ලංකා විභාග දෙපාර්තමේන්තුව ශ්‍රී ලංකා විභාග දෙපාර්තමේන්තුව ශ්‍රී ලංකා විභාග දෙපාර්තමේන්තුව
 இலங்கைப் பரீட்சைத் திணைக்களம் இலங்கைப் பரීட்சைத் திணைக்களம் இலங்கைப் பரීட்சைத் திணைக்களம் இலங்கைப் பரීட்சைத் திணைக்களம் இலங்கைப் பரීட்சைத் திணைக்களம்
 Department of Examinations, Sri Lanka Department of Examinations, Sri Lanka Department of Examinations, Sri Lanka Department of Examinations, Sri Lanka Department of Examinations, Sri Lanka
 ශ්‍රී ලංකා විභාග දෙපාර්තමේන්තුව ශ්‍රී ලංකා විභාග දෙපාර්තමේන්තුව ශ්‍රී ලංකා විභාග දෙපාර්තමේන්තුව ශ්‍රී ලංකා විභාග දෙපාර්තමේන්තුව ශ්‍රී ලංකා විභාග දෙපාර්තමේන්තුව
 இலங்கைப் பரීட்சைத் திணைக்களம் இலங்கைப் பரීட்சைத் திணைக்களம் இலங்கைப் பரීட்சைத் திணைக்களம் இலங்கைப் பரීட்சைத் திணைக்களம் இலங்கைப் பரීட்சைத் திணைக்களம்
 Department of Examinations, Sri Lanka Department of Examinations, Sri Lanka Department of Examinations, Sri Lanka Department of Examinations, Sri Lanka Department of Examinations, Sri Lanka

අධ්‍යයන පොදු සහතික පත්‍ර (උසස් පෙළ) විභාගය, 2015 අගෝස්තු
 கல்விப் பொதுத் தராதரப் பத்திர (உயர் தர)ப் பரீட்சை, 2015 ஓகஸ்ட்
 General Certificate of Education (Adv. Level) Examination, August 2015

තාක්ෂණවේදය සඳහා විද්‍යාව I
 தொழினுட்பவியலுக்கான விஞ்ஞானம் I
 Science for Technology I

67 E I

පැය දෙකයි
 இரண்டு மணித்தியாலம்
 Two hours

Instructions:

- * Answer all the questions.
- * Write your Index Number in the space provided in the answer sheet.
- * In each of the questions 1 to 50, pick one of the alternatives from (1), (2), (3), (4), (5) which is correct or most appropriate and mark your response on the answer sheet with a cross (x) in accordance with the instructions given at the back of the answer sheet.
 (Use of calculators is not allowed.)

1. Microorganisms are always
 - (1) organisms without cellular organization.
 - (2) organisms not observable by the naked eye.
 - (3) organisms without an organized nucleus.
 - (4) organisms successfully adapted to various environmental conditions.
 - (5) chemoautotrophs.
2. What is the respiratory group of acetic acid bacteria used to produce vinegar from coconut toddy?
 - (1) Aerobic
 - (2) Facultative anaerobic
 - (3) Obligate anaerobic
 - (4) Micro aerophilic
 - (5) Facultative aerobic
3. Recombinant DNA technology can be used to produce a transformed organism. The sequential steps from (A) to (E) of this process upto the production of recombinant DNA are given below.
 - (A) Extracting DNA from donor cells.
 - (B) Cutting extracted DNA into fragments.
 - (C) Separating DNA fragments by gel electrophoresis.
 - (D) Identifying DNA fragments containing required genes.
 - (E) Recombining DNA fragments with plasmid DNA.

The steps in which endonuclease and ligase enzymes used in the above process are

 - (1) (A) and (C) only.
 - (2) (B) and (D) only.
 - (3) (B) and (E) only.
 - (4) (C) and (E) only.
 - (5) (D) and (E) only.
4. In a waste water treatment process, the aerobic microbial activity is used in the
 - (1) primary treatment tank.
 - (2) secondary treatment tank.
 - (3) sedimentation tank.
 - (4) disinfectant treatment unit.
 - (5) sludge digester.
5. The amount of heat generated is 604 kJ when 12 g of ethylene (C₂H₄) gas is combusted. The molar mass of C₂H₄ is 28 g mol⁻¹. The balanced equation for the C₂H₄ combustion is given below.

$$\text{C}_2\text{H}_4(\text{g}) + 3\text{O}_2(\text{g}) \longrightarrow 2\text{CO}_2(\text{g}) + 2\text{H}_2\text{O}(\text{g})$$

The heat of reaction of C₂H₄ combustion is

 - (1) -33 kJ
 - (2) -604 kJ
 - (3) -1208 kJ
 - (4) -1409 kJ
 - (5) -7200 kJ
6. The correct statement related to the rate determining step of a reaction is, it is
 - (1) the fastest step of a multi-step reaction.
 - (2) always the first step of a multi-step reaction.
 - (3) always the last step of a multi-step reaction.
 - (4) not affected by catalysts.
 - (5) the slowest step of a multi-step reaction.

7. Activation energy of the forward reaction shown in the energy diagram is

- (1) E_3
- (2) $E_3 - E_2$
- (3) $E_3 - E_1$
- (4) $E_3 + E_2$
- (5) $E_3 + E_1$

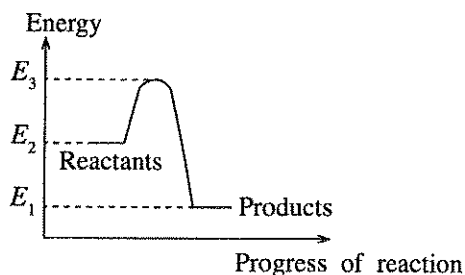

8. Synthetic polymers are always

- (1) thermoplastic.
- (2) crystalline.
- (3) made of monomers.
- (4) highly elastic.
- (5) consists of crosslinks.

9. Which production process is based on non-renewable raw materials?

- (1) Production of fatty acid using plant oil
- (2) Production of soap using plant oil
- (3) Production of ethanol by fermentation of starch
- (4) Extraction of eugenol by cloves
- (5) Production of diesel by crude oil

10. A column made of a burette to separate components of a sample using column chromatography is shown in the figure. The correct order of the materials A, B, C and D which are used to pack the column is

- (1) silica gel, sand, cotton wool, sand
- (2) sand, cotton wool, silica gel, sand
- (3) sand, silica gel, sand, cotton wool
- (4) cotton wool, sand, silica gel, cotton wool
- (5) sand, silica gel, cotton wool, sand

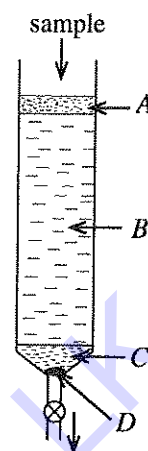

separated components of the sample

11. Which figure shows the correct way to spot a sample (S) and a reference sample (R) on the paper in paper chromatography used to identify the chemical components of a sample?

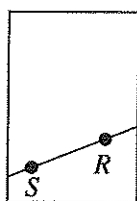

(1)

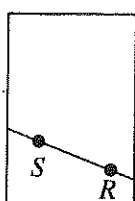

(2)

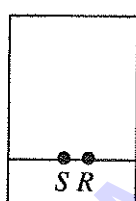

(3)

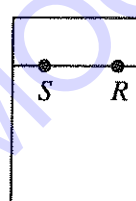

(4)



(5)

12. What is the document to be obtained for recognition and assurance of the rights of an inventor to receive benefits of an invention?

- (1) SLS standard
- (2) Patent
- (3) ISO 14000
- (4) Government registration
- (5) ISO 9000

13. Which of the following groups contain only secondary metabolites?

- (1) Protein, Carbohydrates, Phenols
- (2) Essential oil, Polyphenols, Quinone
- (3) Protein, Essential oil, Carbohydrates
- (4) Lactic acid, Protein, Polyphenols
- (5) Essential oil, Phenols, Carbohydrates

14. Vitamins required to control calcium absorption and blood clotting are respectively,

- (1) A and C
- (2) B and C
- (3) B and D
- (4) D and C
- (5) D and K

15. The true statement regarding chlorofluorocarbon (CFC) is that it

- (1) is a highly unstable gas.
- (2) dissociates under ultraviolet radiation.
- (3) is an industrial gas used for welding of metals.
- (4) is not a greenhouse gas.
- (5) is a naturally produced gas of the earth.

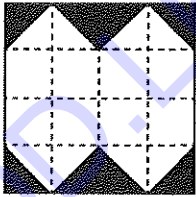
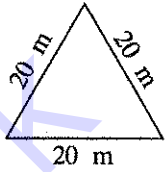
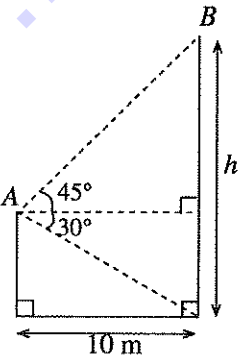
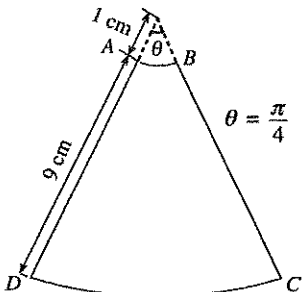
16. Which one of the following statements is true about the ozone layer?
- It is a specific region in the upper atmosphere which consists of only ozone.
 - Only infrared radiation is essential for its existence.
 - Atomic oxygen is essential for the formation of ozone layer.
 - Chlorofluorocarbon (CFC) molecules deplete the ozone layer by directly reacting with ozone.
 - The ozone layer protects the earth from infrared radiation emitted from the sun.
17. The size range of nanoparticle in metres is
- 1 to 10
 - 10^{-1} to 10
 - 10^{-4} to 10^{-2}
 - 10^{-9} to 10^{-7}
 - 10^{-15} to 10^{-13}
18. For a new invention a mechanic removed shaded parts from a flat metal sheet of square shape with a side of 10 cm divided into 16 congruent squares by dotted lines as shown in the figure. The area of the removed metal sheet part is
- 
- 20 cm²
 - 25 cm²
 - 40 cm²
 - 50 cm²
 - 75 cm²
19. A solid object is required to be made of four cubes of a side 1 cm by putting together any two cubes with two of their faces to coincide so that the surface area of the resulting solid is minimum. The surface area of the solid made this way is
- 10 cm²
 - 12 cm²
 - 14 cm²
 - 16 cm²
 - 18 cm²
20. String lines are set out to excavate the foundation of a building with a foundation of a triangular shape with a side of 20 m. To check the accuracy of this setting the distance from a vertex of the triangle set out in string lines to the mid-point of the opposite side was measured. If this triangle set out in string lines is accurate, then the measured distance should be
- 
- 5 m
 - 10 m
 - $10\sqrt{3}$ m
 - 20 m
 - $20\sqrt{3}$ m
21. When the top B of a tower of height h is observed from the top A of a tall building at 10 m distance from the tower as shown in the figure its angle of elevation is 45° and the angle of depression is 30° . Then the height h of the tower is
- 
- 10 m
 - $(40/3)$ m
 - $10\left(1 + \frac{1}{\sqrt{3}}\right)$ m
 - 20 m
 - 40 m
22. A funnel is made of $ABCD$ angular sector cut from a metal sheet with dimensions as shown in the figure. The outer surface area of the body of the funnel is
- 
- $\frac{99\pi}{16}$ cm²
 - $\frac{99\pi}{8}$ cm²
 - $\frac{99\pi}{4}$ cm²
 - $\frac{99\pi}{2}$ cm²
 - $\frac{100\pi}{8}$ cm²
23. Consider the following equations:
- (A) $y = -\frac{1}{2}x$ (B) $y = \frac{1}{2}x$ (C) $y = -\frac{1}{2}x + 2015$
- Out of the above, which equation/s could be perpendicular to the straight line $y = 2x$?
- (A) only.
 - (B) only.
 - (C) only.
 - (A) and (B) only.
 - (A) and (C) only.

24. Consider the positive integer distribution given below.

4, 5, 9, 8, 7, 6, 6, 5, x , y

If the mode of this distribution is 4, then the value of $x + y$ is

- (1) 4 (2) 5 (3) 6 (4) 7 (5) 8
25. What could be the range of six numbers a , 6, 6.5, 7, 9, $2a$ listed in ascending order?
- (1) 2 (2) 2.5 (3) 5 (4) 7 (5) 8
26. The following frequency table shows the actual volumes of water contained in a randomly selected sample of 100 one litre bottles of water from a supermarket.

Volume of water (ml)	Number of bottles
851 – 900	5
901 – 950	85
951 – 1000	5
1001 – 1050	5

The estimated mean volume of water in a bottle to the nearest millilitre is

- (1) 860 (2) 870 (3) 931 (4) 1000 (5) 1020
27. The points A and B have coordinates (2, 2) and (22, 58) respectively. What are the coordinates of the point C on AB that divides the line segment in the ratio $AC : CB = 1 : 3$?
- (1) (12, 30) (2) (7, 16) (3) (17, 44) (4) (30, 12) (5) (16, 7)
28. Which one of the following URLs has syntax errors?
- (1) <http://www.google.com> (2) <http://190.165.21.110/login.php>
 (3) <http://190.165.21.110/index.html> (4) <http://190.165.21/index.html>
 (5) <https://www.youtube.com/watch?v=gFCWZLKc5Hv>
29. Which one of the following is a web search engine?
- (1) Internet Explorer (2) Yahoo! (3) YouTube
 (4) Gmail (5) Twitter
30. Which of the following is **not** a hardware device of a computer?
- (1) CPU (2) Keyboard (3) Operating System
 (4) Motherboard (5) Mouse
31. Consider the following computer devices.
- (A) Mouse (B) Printer
 (C) Keyboard (D) USB flash drive
- Which of the following statements is true regarding the above devices?
- (1) only (A) is an input device. (2) only (B) is an input/output device.
 (3) only (A) and (B) are input devices. (4) only (B) and (C) are output devices.
 (5) only (D) is an input/output device.
32. Consider the following statements about operating systems (OSs) of computers.
- (A) A main function of an operating system is to protect the computer from viruses.
 (B) 'Internet Explorer' is an OS.
 (C) A software that executes on a particular OS can be copied and executed on any other OS without any changes.
 (D) Multiple OSs can be installed on a single computer.
- The true statement/s is/are
- (1) (A) only. (2) (B) only. (3) (C) only. (4) (D) only. (5) (A) and (D) only.
33. In the following email addresses, the address in an **inaccurate** form is
- (1) Sman_Vitanage@example.com (2) Sman.Vitanage@example.com
 (3) Sman@Vitanage@example.com (4) "[Sman@Vitanage](mailto:Sman@Vitanage@example.com)"@example.com
 (5) Sman#Vitanage@example.com
34. In preparing a document by using a typical word processing software, the correct sequence of operations to follow in moving a paragraph in the document from one place to another is
- (1) Cut, place the mouse pointer in the new place, Paste
 (2) Copy, place the mouse pointer in the new place, Paste
 (3) Select, Copy, place the mouse pointer in the new place, Paste
 (4) Select, Cut, place the mouse pointer in the new place, Paste
 (5) Select, Copy, place the mouse pointer in the new place, Copy

35. The cell address A11 of a typical spread sheet contains the formula $=\$A1/\$A\$10$. If this formula is copied to the cell address B11, the formula in B11 cell would be
 (1) $=\$A1/\$A\$10$ (2) $=\$A1/\$B\$10$ (3) $=\$B1/\$A\$10$ (4) $=\$B1/\$B\$10$ (5) $=\$B1/\$A\$11$
36. Consider the following statements about 'rulers' and 'guides' in a presentation software.
 (A) Rulers and guides can be turned on or off as necessary.
 (B) Rulers and guides appear on the slides when slides are printed.
 (C) Rulers and guides help to place objects on the slides.
 (D) Spacing between guide lines cannot be changed as required.

From the above, correct statements are

- (1) (A) and (B) only. (2) (A) and (C) only. (3) (B) and (C) only.
 (4) (B) and (D) only. (5) (C) and (D) only.
37. Consider a part of a spreadsheet and formulae from A to D given below.

- (A) = Count (A1:A4)
 (B) = Sum (A1:A4)
 (C) = Sum ($\$A\$1:\$A\4)
 (D) = Max (A1:A4)

	A
1	25
2	45
3	12
4	18

The formula/formulae that can be included to a cell to obtain the sum of the values in the range of cells from A1 to A4 is/are

- (1) (A) only. (2) (B) only. (3) (A) and (B) only.
 (4) (B) and (C) only. (5) (C) and (D) only.
38. There is a zero error of a vernier calliper due to the gap created between rusted external jaws. To correct the measurement obtained from this apparatus
 (1) the zero error should be added to the reading.
 (2) the zero error should be subtracted from the reading.
 (3) the least count of the apparatus should be added to the reading.
 (4) the least count of the apparatus should be subtracted from the reading.
 (5) the average should be calculated after obtaining several readings.

39. A uniform wooden beam AB is placed horizontally on two vertical supports X and Y as shown in the figure. While X is fixed, Y is moved towards X . The values of normal reactions R_x and R_y from X and Y supports respectively on the beam are

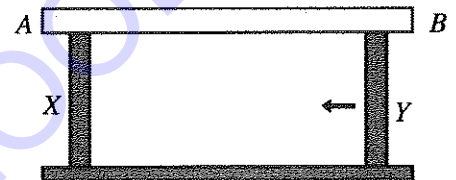

	R_x	R_y
(1)	Decreases	Increases
(2)	Increases	Decreases
(3)	Decreases	Decreases
(4)	Increases	Increases
(5)	No change	No change

40. A concrete cylinder with weight W needs to be rolled from a lower horizontal plane to a higher horizontal plane. The figure shows the ways to apply force from the places A , B , C , D and E on the cylinder. The position to accomplish this action by a force with a minimum magnitude is

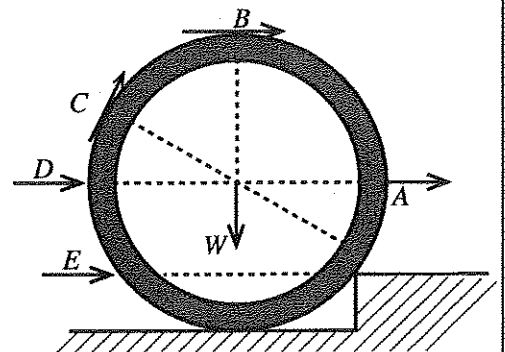

- (1) A
 (2) B
 (3) C
 (4) D
 (5) E
41. The main reason to use water as a radiator coolant for a motor vehicle engine is
 (1) high value of the heat conductivity of water.
 (2) low value of the heat conductivity of water.
 (3) high value of the specific heat capacity of water.
 (4) low value of the specific heat capacity of water.
 (5) high value of viscosity of water.

42. What is the most suitable fuse for an electric fan used in a factory, which is rated as 230 V, 100 W?
 (1) 0.30 A (2) 0.75 A (3) 5.0 A (4) 13 A (5) 15 A

43. As shown in the figure, two wires of aluminium (Al) and copper (Cu) with the same cross sectional area and length are connected to each other to let the current flow. The true statement regarding each wire is,

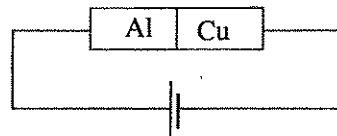

- (1) equal voltage drops across two wires but different currents flow through them.
 (2) equal voltage drops across two wires and equal currents flow through them.
 (3) different voltage drops across two wires but equal currents flow through them.
 (4) different voltage drops across two wires and different currents flow through them.
 (5) rate of heat dissipation of each wire is equal.
44. The number of turns of the primary and secondary coils of a transformer is 500 and 125, respectively. When 240 V alternative voltage is supplied to the primary coil, the output voltage of the secondary coil is
 (1) 60 V (2) 80 V (3) 120 V (4) 320 V (5) 480 V

45. The following data are given about a wire under tension within the proportional limit.

Applied external force on the wire	= 100 N
Cross sectional area of the wire	= 10^{-6} m^2
Extension of the wire	= $2 \times 10^{-3} \text{ m}$
Unstretched length of the wire	= 2 m

According to the above data, the Young's modulus of the material made of the wire is

- (1) 10^3 N m^{-2} (2) 10^6 N m^{-2} (3) 10^8 N m^{-2} (4) 10^{11} N m^{-2} (5) 10^{14} N m^{-2}
46. The weight of a glass stopper when measured using a spring balance in the air is 2.4 N. When it is fully immersed in water, the weight is 2 N. The density of water is 1000 kg m^{-3} and the acceleration of gravity is 10 m s^{-2} . The density of the glass stopper material in kg m^{-3} is
 (1) 1200 (2) 2000 (3) 4000 (4) 6000 (5) 8000
47. Consider the following statements on the mechanism of hydraulic brake system of a motor vehicle.

- (A) The brake activates due to the transmitted additional pressure by the force applied on the brake pedal exerted on the fluid in the main cylinder to the piston in the brake cylinder.
 (B) An increased pressure created due to the additional pressure applied on the fluid by the pedal is exerted on the piston in the brake cylinder.
 (C) A frictional torque exerts on the brake disc due to the additional pressure on the piston in the brake cylinder.

Of the above statements

- (1) only (A) is true. (2) only (B) is true.
 (3) only (A) and (B) are true. (4) only (A) and (C) are true.
 (5) only (B) and (C) are true.
48. The speed at which water flows through a uniform rubber tube with 1 cm internal diameter is 2 m s^{-1} . If a nozzle with 0.2 cm internal diameter is fixed at the end of the tube, the speed at which water is emitted from the nozzle is
 (1) 0.04 m s^{-1} (2) 2 m s^{-1} (3) 5 m s^{-1} (4) 10 m s^{-1} (5) 50 m s^{-1}
49. A rotating disc which is fixed horizontally to rotate freely about a vertical axis through the center has a moment of inertia 200 kg m^2 . The angular acceleration of the disc due to the applied 2 N m torque, which is tangential to the rim of the rotating disc is
 (1) 0.01 rad s^{-1} (2) 0.01 rad s^{-2} (3) 0.05 rad s^{-1} (4) 10 rad s^{-1} (5) 10 rad s^{-2}
50. Consider the statements given below about an object moving along a circular path with a uniform angular velocity.

- (A) The speed of the object at any point is constant.
 (B) The resultant acceleration acting on the object is zero.
 (C) A centripetal force is acting on the object while its magnitude is constant.

Of the above statements

- (1) only (A) is true. (2) only (B) is true.
 (3) only (A) and (B) are true. (4) only (A) and (C) are true.
 (5) only (B) and (C) are true.

සියලු ම හිමිකම් ඇවිරිණි / முழுப் பதிப்புரிமையுடையது / (All Rights Reserved)

ශ්‍රී ලංකා විභාග දෙපාර්තමේන්තුව ශ්‍රී ලංකා විභාග දෙපාර්තමේන්තුව ශ්‍රී ලංකා විභාග දෙපාර්තමේන්තුව ශ්‍රී ලංකා විභාග දෙපාර්තමේන්තුව ශ්‍රී ලංකා විභාග දෙපාර්තමේන්තුව
 இலங்கைப் பரீட்சைத் திணைக்களம் இலங்கைப் பரීட்சைத் திணைக்களம் இலங்கைப் பரීட்சைத் திணைக்களம் இலங்கைப் பரීட்சைத் திணைக்களம் இலங்கைப் பரීட்சைத் திணைக்களம்
 Department of Examinations, Sri Lanka Department of Examinations, Sri Lanka Department of Examinations, Sri Lanka Department of Examinations, Sri Lanka Department of Examinations, Sri Lanka
 இலங்கைப் பரීட்சைத் திணைக்களம் இலங்கைப் பரීட்சைத் திணைக்களம் இலங்கைப் பரීட்சைத் திணைக்களம் இலங்கைப் பரīட்சைத் திணைக்களம் இலங்கைப் பரīட்சைத் திணைக்களம்
 Department of Examinations, Sri Lanka Department of Examinations, Sri Lanka Department of Examinations, Sri Lanka Department of Examinations, Sri Lanka Department of Examinations, Sri Lanka

අධ්‍යයන පොදු සහතික පත්‍ර (උසස් පෙළ) විභාගය, 2015 අගෝස්තු
கல்விப் பொதுத் தராதரப் பத்திர (உயர் தர)ப் பரீட்சை, 2015 ஆகஸ்ட்
General Certificate of Education (Adv. Level) Examination, August 2015

කාක්ෂණවේදය සඳහා විද්‍යාව II தொழினுட்பவியலுக்கான விஞ்ஞானம் II Science for Technology II	67 E II	පැය තුනයි மூன்று மணித்தியாலம் Three hours
---	----------------	--

Index No. :

Important :

- * This question paper consists of 12 pages.
- * This question paper comprises of Parts A, B, C and D. The time allotted for all parts is three hours.

(Use of calculators is not allowed.)

Part A - Structured Essay (08 pages)

- * Answer all the questions on this paper itself.
- * Write your answers in the space provided for each question. Note that the space provided is sufficient for your answers and that extensive answers are not expected.

Parts B, C and D - Essay (04 pages)

- * Select minimum of one question from each of the parts B, C and D and answer four questions only. Use the papers supplied for this purpose. At the end of the time allotted for this paper, tie all parts together so that Part A is on the top of Parts B, C and D before handing over to the supervisor.
- * You are permitted to remove only Parts B, C and D of the question paper from the examination hall.

For Examiners' Use Only

Part	Q. No.	Marks
A	1	
	2	
	3	
	4	
B	5	
	6	
C	7	
	8	
D	9	
	10	
Total		
Percentage		

Final Marks

In Numbers	
In Words	

Code Numbers

Marking Examiner 1	
Marking Examiner 2	
Checked by	
Supervised by	

Do not write in this column

PART A – Structured Essay
 Answer all questions on this paper itself.

1. (a) (i) Write **two** major differences between fungi and bacteria.

- (1)
- (2)

(ii) The diagram shown below is the typical structure of a yeast cell which is used to produce alcohol. Name the parts labelled from P to T.

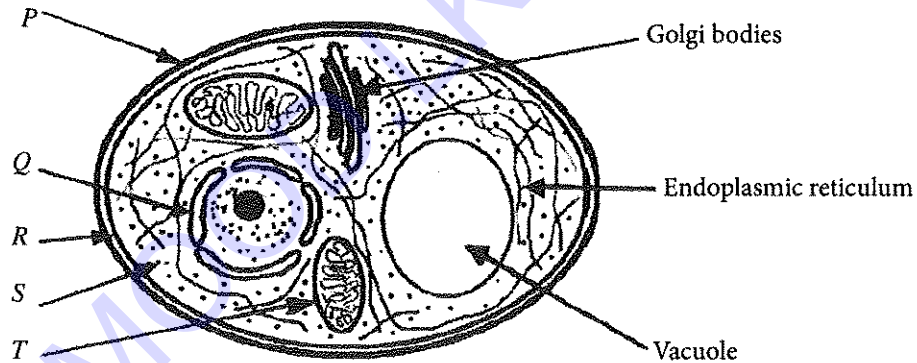

- P.
- Q.
- R.
- S.
- T.

(iii) Four industries which use microorganisms are indicated in table A. Select a suitable example of microorganism for each industry from table B and complete table A.

Table A

Table B

Industry	Example	Microorganisms
1. Bakery		<i>Acetobacter</i> spp.
2. Amino acid production		<i>Saccharomyces cerevisiae</i>
3. Yogurt		<i>Corynebacterium glutamicum</i>
4. Vinegar		<i>Streptococcus thermophilus</i>

(iv) Write **two** optimal conditions required for the efficient production of compost.

- (1)
- (2)

Do not write in this column

(b) Structures A, B and C of some carbohydrates are given below.

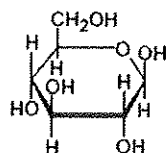

Structure A

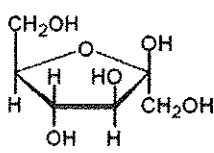

Structure B

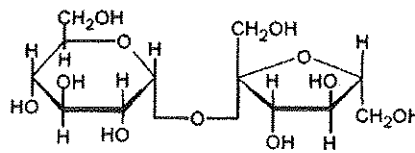

Structure C

(i) Complete the table given below based on the structures A, B and C.

Structure	Name of the carbohydrate	Type of the carbohydrate
A		
B		
C		

(ii) From the structures A, B and C given above, what is the main carbohydrate found in cane sugar?

(iii) Complete the following table based on the observations of an experiment performed using glucose and Benedict solutions.

Solution mixture	Colour
Benedict solution + glucose solution (After heating)

(iv) Plant cell wall mainly consists of a polymer made of simple sugar molecules. What is this polymer?

(v) Write the main types of polysaccharides used to store energy in living organisms in the table given below.

Plants
Animals

(vi) What is the group of biomolecules formed in the amino acid polymerization?

(vii) Name a reagent that can be used in the school laboratory to identify the group of biomolecules mentioned in part (b)(vi)?

(viii) An enzyme is a biomolecule that is having a catalytic power. The energy diagram of energy versus the progression of reaction is given for an industrial production process, which is performed using a typical enzyme. Draw the energy curve in the absence of an enzyme, on the same diagram given below.

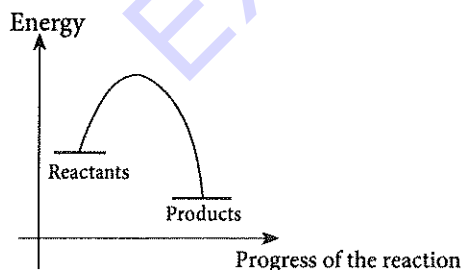

(ix) State two factors that can change the activity of the above enzyme.

(1)

(2)

Q.1

100

2. In a new method proposed to develop candles, a mixture of paraffin wax and plant-based saturated triglycerides is heated to obtain a liquid mixture. Cooled liquid wax is mixed with essential oils in order to produce candles with various fragrances.

(a) (i) Which type of a system can a burning candle be classified into based on its energy and matter exchange?

.....

(ii) Mention **two** molecular level differences between solid wax and liquid wax.

(1)

(2)

(b) An experimental setup used to study the changes in physical properties of prepared mixtures according to the new method is given below with the experimental results.

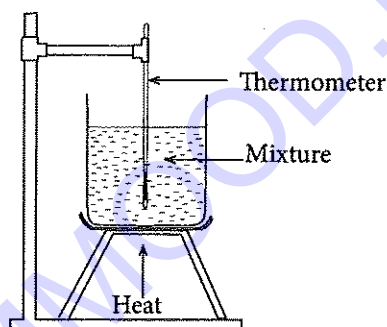

Percentages of wax and triglyceride in the mixture	Minimum temperature of the mixture becomes fully liquid
Pure wax	65 °C
50% wax and 50% saturated triglyceride	63 °C
30% wax and 70% saturated triglyceride	57 °C

(i) Which physical property of the wax mixture can be studied using the above experiment?

.....

(ii) With the addition of saturated triglyceride what change can be observed in the studied physical property?

.....

(iii) The chemical formula of a main hydrocarbon (alkane) found in wax is $C_{24}H_{50}$. What are the products made in the complete combustion of the hydrocarbon?

.....

(iv) Write down the balanced chemical equation for the complete combustion of the above hydrocarbon.

.....

(v) Mention **two** main factors that must be satisfied for a reaction between a hydrocarbon in the gaseous state and O_2 molecules.

(1)

(2)

(c) An experimental setup to determine the combustion rate of a candle made using the new method and its readings are shown below.

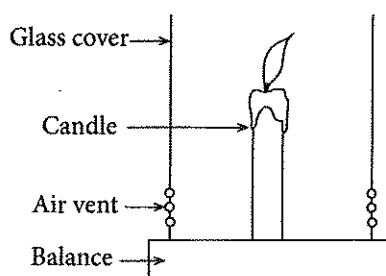

Time/min	Mass of the candle/g
0	10.5
2	9.8
4	9.1
8	8.5
10	7.7
12	7.0

Do not write in this column

(i) Indicating the relevant steps, calculate the average combustion rate of the candle in g/min within the first 8 minutes.

.....

(ii) Mention **one** possible error that can occur in the above combustion rate determining experiment.

.....

(iii) Mention **one** economical advantage of this saturated triglyceride based candle manufacturing process. Assume that the specific heat capacity of wax does not change due to triglyceride.

.....

(iv) In this proposed method 50% to 70% of saturated triglycerides can be mixed with wax. Mention one environmental benefit of this new method.

.....

Q.2

100

3. A cylindrical hole with the diameter of about 9 mm is made in a metallic cube with a side of about 1 cm as shown in the below figure. It is required to find the density of the metal type that the object was made.

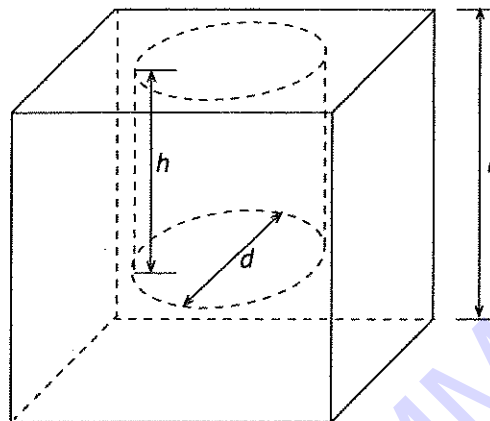

Required measurements can be taken by selecting suitable measuring equipment given below.

Triple beam balance, vernier calliper, travelling microscope, micrometer screw gauge and meter ruler.

(a) The following measurements have to be taken to find the volume of the object.

Write down the necessary equipment from the above list.

Side of the cube (l):

Diameter of the hole (d):

Depth of the hole (h):

(b) Complete the table given below in terms of l , d and h .

Section required to find the volume	Expression for the volume
Cube before the hole was made	
The hole made in the cube	
Cube after the hole was made	

Do not
write
in this
column

(c) If the depth of the hole is measured as 4.3 mm, calculate the percentage error of the measurement.

.....

(d) What is the other measurement (x) required in addition to the measurements obtained in above part (a) to calculate the density of the cube material?

.....

(e) Write down an expression for the density of the object's material (ρ) in terms of the volume (V) of the object and x .

.....

(f) What are the **two** measurements should be obtained in an experiment to determine the volume of the object using only a measuring cylinder and water.

(1)

(2)

(g) A student mentioned that the volume of the solid object can be found more accurately by the method in part (f).

(i) Do you agree with this statement?

(ii) Give reasons for the answer in part (g)(i).

.....

(h) Archimedes principle is used by another student to find the density of the material of the object. First, the solid object is weighed in air using a spring balance and the weight obtained is W_1 . The weight of the object obtained when it is completely immersed in water is W_2 .

Write down expressions for the given physical quantities in the table using **only** the volume of the object V , the gravitational acceleration g , the density of the material ρ_m and the density of water ρ_w .

Physical quantity	Expression
The weight of the object, W_1
The upthrust in water, U
Relative density of the material of the object

Q.3

100

Do not write in this column

4. A steam generator (boiler) used to produce steam is shown in the figure. Inside the boiler, tube A is immersed in water and tube B is kept above the water level.

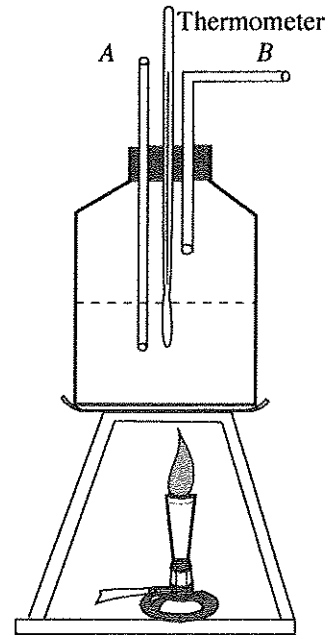

(a) (i) What is the requirement to have tube A as a safety precaution?

.....

(ii) What is the reason to keep tube B above the water level?

.....

(iii) When heat is supplied continuously to the steam generator, the reading of the thermometer gradually rises and eventually becomes constant. Briefly explain the reason for this.

.....

.....

(b) When some amount of steam from the steam generator is added to water in an insulated calorimeter, the temperature of water rises gradually and reaches a maximum value.

(i) In addition to the specific heat capacity of water, two other values should be found experimentally to find the amount of heat received by water. Name these two values.

(1)

(2)

(ii) What are the four measurements required to find the two values named in part (b)(i) above?

(1)

(2)

(3)

(4)

(iii) Water in the calorimeter receives heat from the steam at 100 °C in two steps. Write down these two steps.

(1)

(2)

(iv) Write down the two measurements required to calculate the mass of steam added to water in the calorimeter.

(1)

(2)

(v) If the specific latent heat of vaporization, specific heat capacity of water, mass and temperature of the steam are given, what is the other measurement required to calculate the amount of heat received by water in the calorimeter from the steam?

.....

(c) The specific latent heat of vaporization of water can be calculated with the measurements obtained above.

(i) Write down the relationship between the heat received from water and the calorimeter, and the heat emitted from the steam as an equation. Assume that the heat loss to the environment is negligible.

.....

(ii) To obtain accurate experimental results, only dry steam without condensed water droplets should be added to water in the calorimeter. A steam trap is used for this. Sketch a suitable diagram for a steam trap.

(iii) Mention the error that can occur if the steam generator and the calorimeter are kept very close.

Do not
write
in this
column

Q.4

100

**

සියලු ම හිමිකම් ඇවිරිණි / முழுப் பதிப்புரிமையுடையது / All Rights Reserved

ශ්‍රී ලංකා විභාග දෙපාර්තමේන්තුව ශ්‍රී ලංකා විභාග දෙපාර්තමේන්තුව ශ්‍රී ලංකා විභාග දෙපාර්තමේන්තුව ශ්‍රී ලංකා විභාග දෙපාර්තමේන්තුව ශ්‍රී ලංකා විභාග දෙපාර්තමේන්තුව
 இலங்கைப் பரீட்சைத் திணைக்களம் இலங்கைப் பரීட்சைத் திணைக்களம் இலங்கைப் பரීட்சைத் திணைக்களம் இலங்கைப் பரීட்சைத் திணைக்களம் இலங்கைப் பரීட்சைத் திணைக்களம்
 Department of Examinations, Sri Lanka Department of Examinations, Sri Lanka Department of Examinations, Sri Lanka Department of Examinations, Sri Lanka Department of Examinations, Sri Lanka
 இலங்கைப் பரීட்சைத் திணைக்களம் இலங்கைப் பரීட்சைத் திணைக்களம் இலங்கைப் பரීட்சைத் திணைக்களம் இலங்கைப் பரīட்சைத் திணைக்களம் இலங்கைப் பரīட்சைத் திணைக்களம்
 Department of Examinations, Sri Lanka Department of Examinations, Sri Lanka Department of Examinations, Sri Lanka Department of Examinations, Sri Lanka Department of Examinations, Sri Lanka

අධ්‍යයන පොදු සහතික පත්‍ර (උසස් පෙළ) විභාගය, 2015 අගෝස්තු
 கல்விப் பொதுத் தராதரப் பத்திர (உயர் தர)ப் பரீட்சை, 2015 ஆகஸ்ட்
 General Certificate of Education (Adv. Level) Examination, August 2015

තාක්ෂණවේදය සඳහා විද්‍යාව II
 உயிரமுறைமைகள் தொழினுட்பவியல் II
 Science for Technology II

67 E II

Essay

* Select minimum of one question each from parts B, C and D and answer four questions only.
 * Give clearly labelled diagrams where necessary.
 (Each question carries 15 marks.)

Part B - Essay

5. The final marks of 20 students in a mathematics examination are given below.
 40, 35, 60, 30, 45, 50, 65, 25, 20, 80, 80, 20, 25, 70, 75, 15, 30, 20, 55, 55
- (a) Calculate the first quartile, the second quartile and the third quartile.
 (b) Calculate the inter quartile range.
 (c) If final marks are $x_1, x_2, x_3, \dots, x_{20}$ then $\sum_{i=1}^{20} (x_i - 45) = -5$. Hence calculate the mean of the final marks.
 (d) As the mean of the final marks is low, examiners decide to standardize them. With justification calculate the mean of standardized marks in the following standardization methods using the mean found in part (c).
 (i) Adding 5 marks to each final mark
 (ii) Increasing each final mark by 10%
 (e) Show that the inter quartile range found in above part (b) does not change in part (d)(i), but it changes in part (d)(ii).
6. (a) Show that the volumes of a closed spherical tank of radius 3 m and a closed right circular cylinder of radius 3 m and height 4 m are equal.
 (b) The expected production cost of spherical tank and right circular cylindrical tank per square metre are Rs 20 000/= and Rs 15 000/= respectively. Show that it is cheaper to build the cylindrical tank by calculating the production cost of each of these two tanks.
 (c) Three right circular cylindrical tanks of radius 3 m and height 4 m are to be placed on a flat land with the centres of the circular bottom of the tanks at the vertices of an equilateral triangular area of side 7 m as shown in the figure.

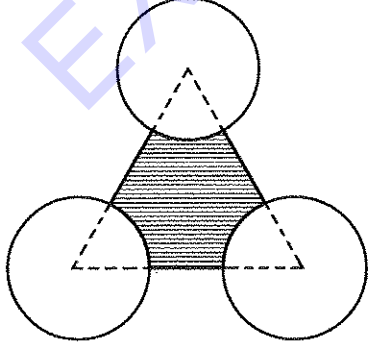

- (i) Calculate the area of this triangle.
 (ii) The area of this triangle not covered by the cylindrical tanks has to be calculated. This is shown by the shaded area in the above figure. Calculate this area.

Part C - Essay

7. (a) Global warming is a major environmental problem that is currently faced.
- Briefly explain the greenhouse effect.
 - In addition to water vapour, name **four** major greenhouse gases in the earth atmosphere.
 - State **one** human activity for each greenhouse gas that you have mentioned in question (ii) which is released to the atmosphere.
 - Explain briefly how greenhouse gases contribute to the global warming.
 - State **five** adverse effects that are considered to be happening due to the global warming.
- (b) Water pollution is taking place at an alarming rate due to human and industrial activities.
- State **five** major water polluting agents.
 - Briefly explain what is Biochemical Oxygen Demand (BOD).
 - Briefly explain how secondary water treatment reduces BOD.
 - Briefly explain what is water disinfection.
 - Name **three** methods that can be used for water disinfection.

8. (a) Organic compound **A** is dissolved in viscous organic solvent **E**. Gas **B** does not react with the organic solvent **E** while gas **B** reacts with compound **A** as given below.



This reaction is performed industrially at an optimum temperature of 70 °C and the pressure of 1.2 atm. Under these conditions **A**, **D** and **E** are at liquid state. The reaction chamber designed for this industrial process is shown below.

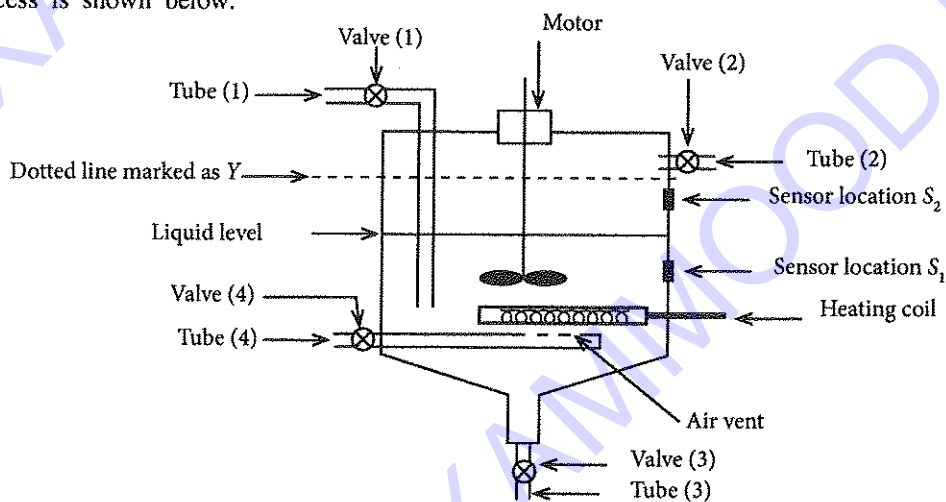

In the above setup, a tube connected to reaction chamber can be used to transport only one medium. Temperature and pressure sensors are required to be fixed to the reaction chamber.

- List the suitable tubes that can be used to transport gas **B**. Out of the tubes listed, what is the most appropriate tube? Give a reason for your selection.
- What are the **two** substances that can be transported using the tube number (2)?
- Out of the two sensor locations S_1 and S_2 , select the most suitable location to fix a thermometer to measure the temperature of the reaction medium. State the reason briefly.
- It is **not** recommended to perform the reaction when the organic medium is filled up to the dotted line marked as **Y**. Give **one** main reason.

- (b) Caffeine is a secondary metabolite. Thin layer chromatography (TLC) can be used in the laboratory to determine the purity of a caffeine sample extracted from tea leaves by a new method. The solvent chamber used for the TLC experiment and the developed TLC plate after the experiment are shown in figures given below. The spotted caffeine sample (S) and the control sample (R) on the TLC plate at the beginning of the experiment are shown.

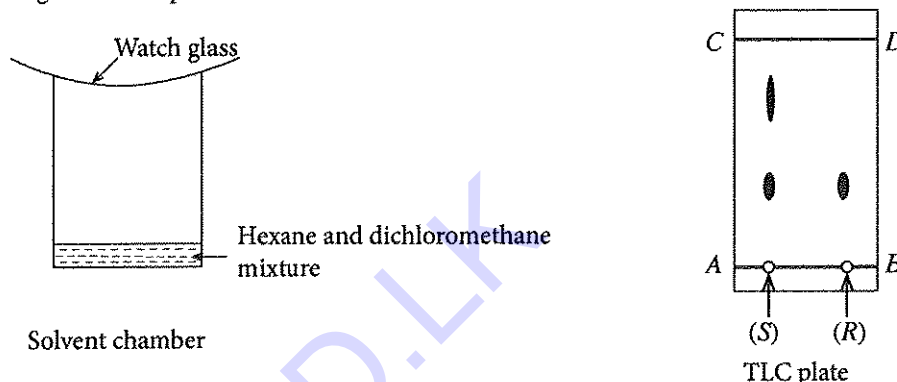

- What are the main materials used for mobile and stationary phases in this TLC experiment?
- Briefly explain why it is necessary to keep the solvent chamber closed after adding the solvent mixture prior to placing the TLC plate.
- State two factors that must be considered when drawing the baseline (AB line) in TLC.
- What must be used to spot the sample on the TLC plate?
- What can you say about the purity of extracted caffeine sample based on the TLC experimental results?
- State basic steps to be followed in recrystallizing impure natural product extract.
- Explain why some secondary metabolites are required to be synthesized chemically although they can be extracted from natural sources.

Part D - Essay

9. For a water supply of a house, a tank of mass 50 kg and capacity 2 m^3 is used. The tank is kept on a concrete slab of mass 1750 kg which is placed on four uniform concrete columns of height 10 m, mass 1500 kg and cross sectional area $25 \text{ cm} \times 25 \text{ cm}$ each as shown in the figure. Consider the density of water is 1000 kg m^{-3} .

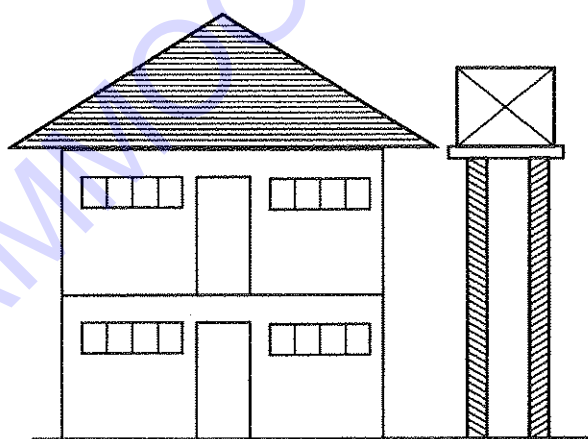

- When the tank is filled completely with water,
 - find the mass of water in the tank.
 - what is the net force acting on four concrete columns?
 - what is the pressure on the ground due to one column?
 - suggest a method to reduce the pressure on the ground due to a column.
- Water is supplied to the tank by an electric water pump from a well of depth 30 m. The pump is fixed at ground level and it pumps water to the tank at a height of 10 m at a rate of 60 litres per minute. Water is released from the tube at a speed of 2 m s^{-1} .
 - Find the mass of water lifted per second.
 - Calculate the potential energy acquired by the water released from the end of the tube per second by taking the bottom of the well as the zero potential level.
 - Calculate the kinetic energy of the water released from the end of the tube per second.
 - Find the output power and the efficiency of the electric water pump under the given conditions, when the pump consumes electrical energy at a rate of 1000 W.

10. (a) (i) A potential difference V is supplied across an electrical equipment and a current I flows through it. Write down an expression for the rate of energy dissipation of the equipment.
- (ii) A current I flows through a resistor R . Write down an expression for the rate of heat dissipation P across the resistor R .
- (b) The voltages of national electric supply of two countries are 240 V and 120 V.
- (i) Two electric kettles rated 240 V, 1 kW and 120 V, 1 kW are connected to 240 V and 120 V supply voltages, respectively. Find the current flowing through each kettle.
- (ii) If conducting wires with same resistance are used to connect the kettles to the main supply, explain which circuit generates more heat.
- (iii) Suggest a method to reduce energy loss of the circuit mentioned in above part (b)(ii). Consider that the supply voltage cannot be changed.
- (c) Two houses situated at a distance of 1 km from two electricity distributing centers of 120 V and 240 V voltages are shown below. Copper (Cu) and aluminium (Al) wires of cross sectional area $8 \times 10^{-6} \text{ m}^2$ can be used for the transmission of electricity. The resistivity of copper is $1.7 \times 10^{-8} \Omega \text{ m}$ and its density is 8900 kg m^{-3} , and these values for aluminium are $2.5 \times 10^{-8} \Omega \text{ m}$ and 2800 kg m^{-3} respectively.

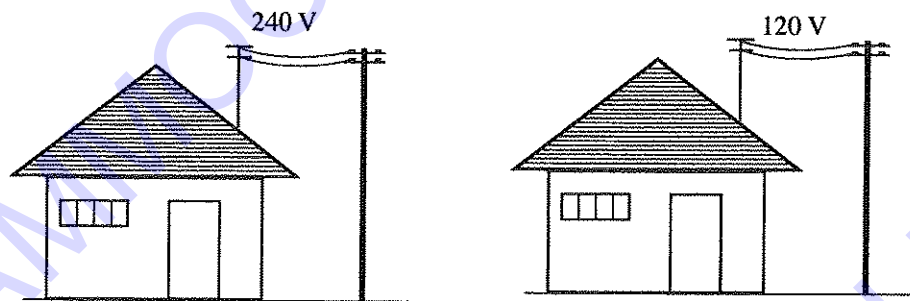

- (i) Using the given data, calculate the resistance and the mass of copper and aluminium wires used.
- (ii) State an advantage and a disadvantage of using each type of wire.
- (iii) The following table shows the power of electrical equipment, number of equipment use and the number of hours use daily in a house. If the cost for one unit of electric power (1 kW h) is Rs. 20/= calculate the electricity bill for a month of 30 days.

Electric equipment	Power of each equipment (W)	Number of equipment use	Number of hours use daily (h)
Bulb	11	8	5
Fan	50	5	12
Refrigerator	70	1	24
Kettle	1500	1	1
Iron	750	1	$\frac{1}{2}$
